

Sage Commercial Served Door A-Fix Cedar Installation



Check your packing crate contains

- Sage roller shutter in head case
- A pair of guides
- A pair of socket bolts
- Cedar screw covers

SAGE COMMERCIAL DOORS REQUIRE A MINIMUM OF 2 PEOPLE TO INSTALL.

A-FIX INSTALLATION (door fixed to face of jambs)

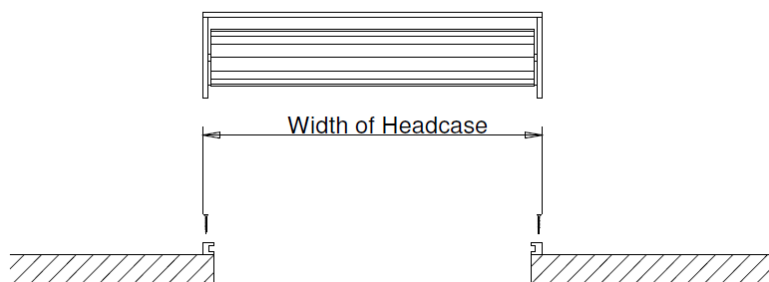

1. Screw the guides to the jambs, keeping them plumb and level.

2. With the guides in place check the overall width at the top and bottom. This will be the same width as the head case.

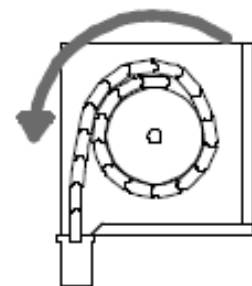

3. Pull the screen into installation position as shown above.

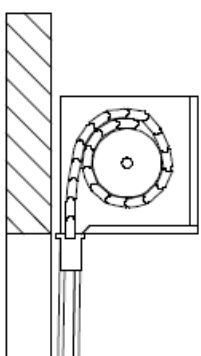

4. Holding the head case in its correct position, loosen the top screws from the guides and tilt to allow the door to be pulled down the guides. Push guides back into position and tighten screws.

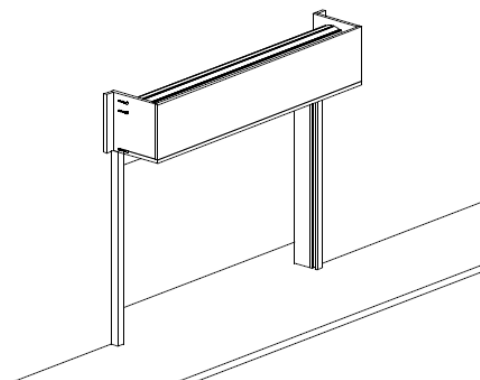
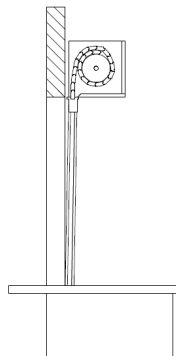

5. With the door pulled down in its closed position, the head case can now be fixed in place by screwing through the wings.

Things to remember:

- Your door has been tensioned in the factory and will not require any more tension
- Please inform the operators not to slam the door up or down but to ease it with both hands
- We suggest fixing a cover board on the top of the head case when it has been installed to keep the dust out.
- Please do not roll the door up until your lacquer or finishing coats have completely dried!

Sage Doors.....for quality rollers doors that keep on rolling

Sage Commercial Servery Door B-Fix Cedar Installation



Check your packing crate contains

- Sage roller shutter in head case
- A pair of guides
- A pair of socket bolts
- Cedar screw covers

SAGE COMMERCIAL DOORS REQUIRE A MININIUM OF 2 PEOPLE TO INSTALL.

B-FIX INSTALLATION (door fixed between jambs)

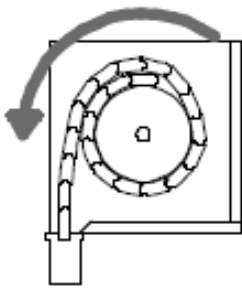

1. Pull the screen into installation position as shown above.

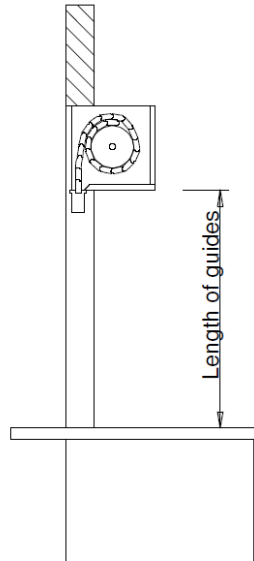

2. Fix the head case into its correct position.

3. With the head case in place check the overall length of the guides. This will be the same as the length from the bottom of the head case to the bench top.

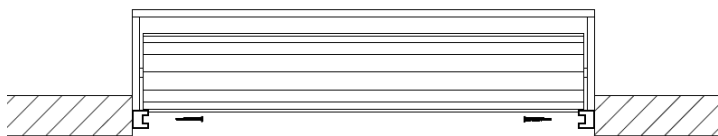

4. Screw the guides to the jambs, keeping them plumb and level.

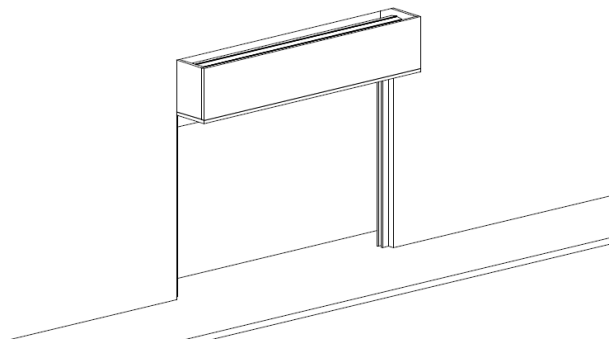

5. The door can now be pulled down the guides.

Things to remember:

- Your door has been tensioned in the factory and will not require any more tension
- Please inform the operators not to slam the door up or down but to ease it with both hands
- We suggest fixing a cover board on the top of the head case when it has been installed to keep the dust out.
- Please do not roll the door up until your lacquer or finishing coats have completely dried!

Sage Doors.....for quality rollers doors that keep on rolling

Sage Commercial Served Door A-Fix Aluminium Installation

SAGE 
DOORS

Check your packing crate contains

- Sage roller shutter in head case
- A pair of guides
- A pair of socket bolts

SAGE COMMERCIAL DOORS REQUIRE A MINIMUM OF 2 PEOPLE TO INSTALL.

A-FIX INSTALLATION (door fixed to face of jambs)

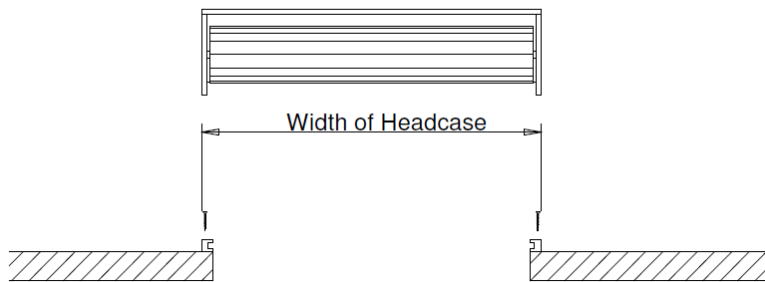

1. Screw the guides to the jambs, keeping them plumb and level. Take care not to scratch the guides

2. With the guides in place check the overall width at the top and bottom. This will be the same width as the head case.

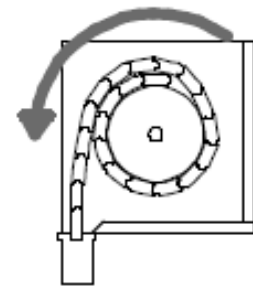

3. Pull the screen into installation position as shown above.

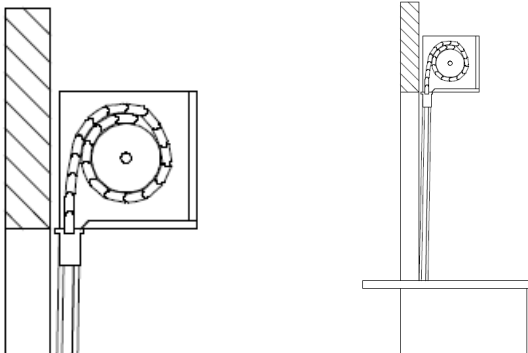

4. Holding the head case in its correct position, with the bottom rail out.

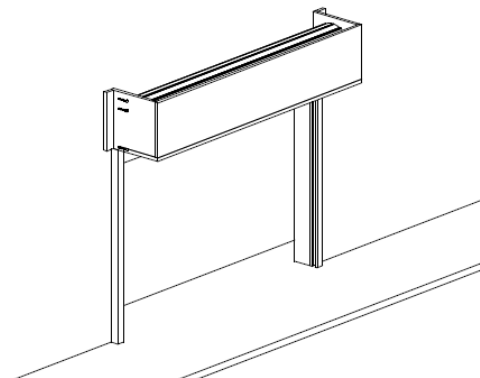

5. With the door pulled down in its closed position, the head case can now be fixed in place by screwing through the wings.

Things to remember:

- Your door has been tensioned in the factory and will not require any more tension
- Please inform the operators not to slam the door up or down but to ease it with both hands
- We suggest fixing a cover board on the top of the head case when it has been installed to keep the dust out.
- Please do not roll the door up until your lacquer or finishing coats have completely dried!

Sage Doors.....for quality rollers doors that keep on rolling

Sage Commercial Servery Door B-Fix Aluminium Installation

SAGE
DOORS

Check your packing crate contains

- Sage roller shutter in head case
- A pair of guides
- A pair of socket bolts

SAGE COMMERCIAL DOORS REQUIRE A MINIMUM OF 2 PEOPLE TO INSTALL.

B-FIX INSTALLATION (door fixed between jambs)

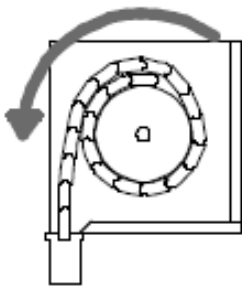

1. Pull the screen into installation position as shown above.

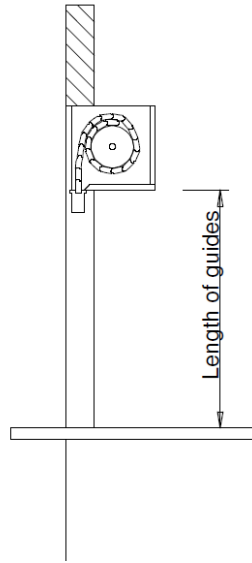

2. Fix the head case into its correct position.

3. With the head case in place check the overall length of the guides. This will be the same as the length from the bottom of the head case to the bench top.

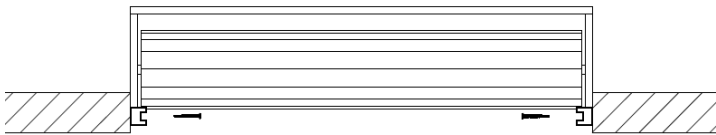

4. Screw the guides to the jambs, keeping them plumb and level.

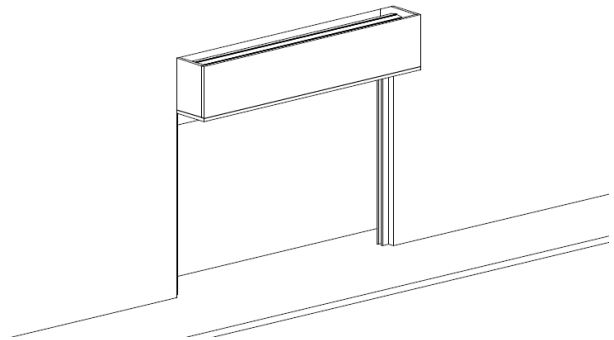

5. The door can now be pulled down the guides.

Things to remember:

- Your door has been tensioned in the factory and will not require any more tension
- Please inform the operators not to slam the door up or down but to ease it with both hands
- We suggest fixing a cover board on the top of the head case when it has been installed to keep the dust out.
- Please do not roll the door up until your lacquer or finishing coats have completely dried!

Sage Doors.....for quality rollers doors that keep on rolling