

Sage Doors Ltd

Please do NOT read this unless you want your installation to go smoothly!

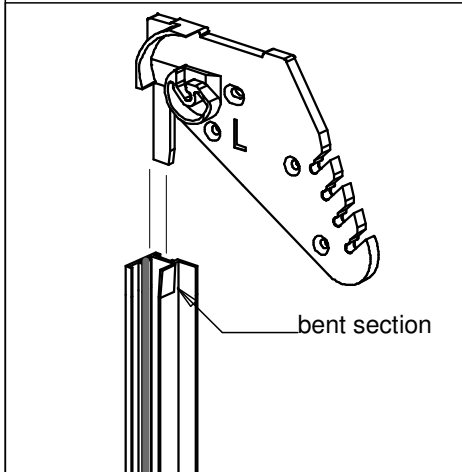

1. Slide the bent end of the aluminium track over the leg of the plastic bracket. Please NOTE, that the leg on the bracket does not need to be cut on this model door.

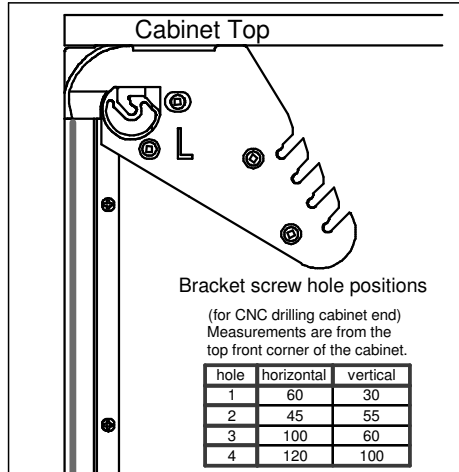

2. Place the bracket and track flush with the front of the cabinet. Fix in place with the 8 x 19 screws provided. Start with the adjustable slot hole first. Best Results are achieved by pre-drilling a 5 mm hole, 2 mm deep. Fix aluminium tracks with 6 x 1/2 pan head screws provided.

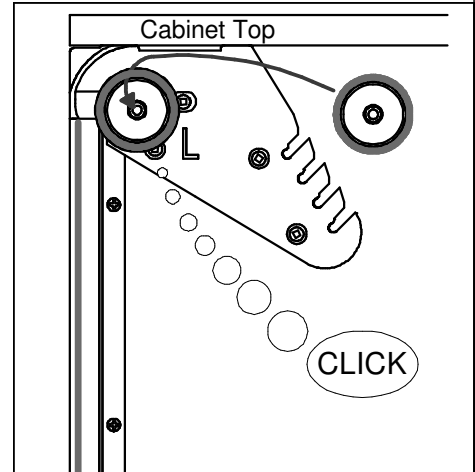

3. To insert Idle roller into bracket, slide the roller towards you along the bottom of the top, then push it down and back into the slot. Both ends should Click in.

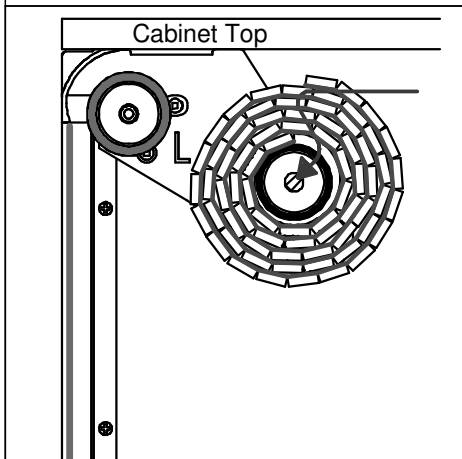

4. To place the door into the brackets, slide the door towards you along the top, then slide it down the back of the brackets until the ends drop into the slots. You may have to rotate the door a little so it drops in. The left end should click in. Check both ends are in the same hole.

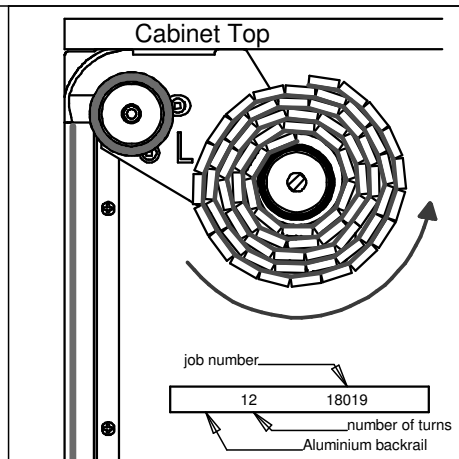

5. To Tension the spring, rotate the door in the direction marked, for the number of turns written on the backrail. Backrail in drawing is example only.

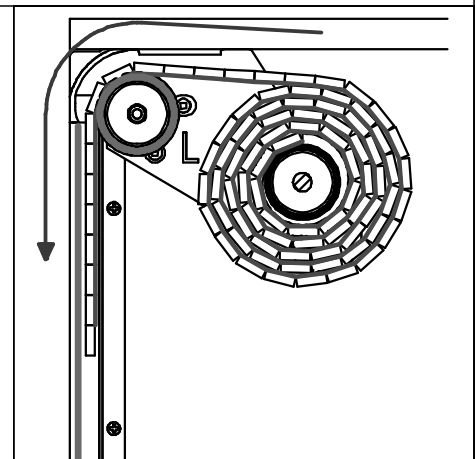

6. Roll the end of the door over the Idle roller and feed it down into the tracks. Lift the door up and down and test the tension. If required, adjust the number of turns.

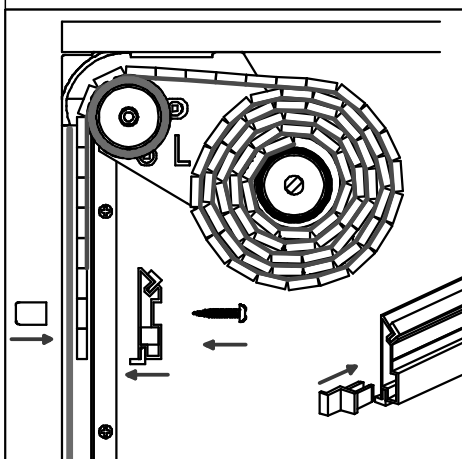

7. Decide which of the two buffer strips you want shown on the bottom of the door. Swap the two if required. Check the backrail plugs are inserted as shown, aluminium doors don't have these plugs. Fix the backrail and the handle on with the 8 x 25 screws

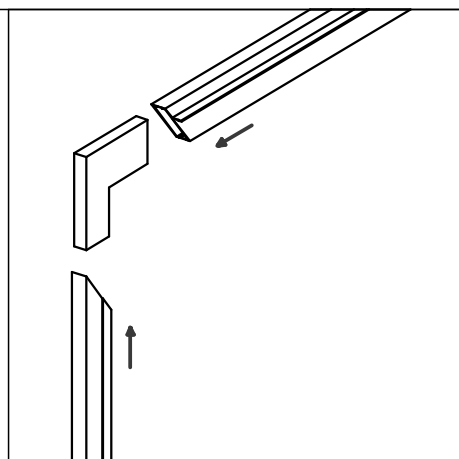

8. This step applies if your door contains the optional Aluminium surround. Slide the MDF corners into the mitred ends of the fascia and Pelmet. Hold together with the 4 x 12 screws provided. Take care while fixing the screws not to mark the face of the Aluminium.

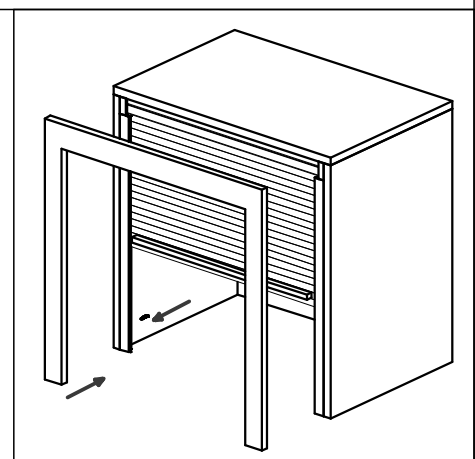

9. Set your surround in place. Fix with 6 x 12 mm screws. Aluminium surround must be pre-drilled with a 3 mm hole, and the track must be pre-drilled with a 3.5 mm hole.

Easy to install, easy to operate
Choose Sage Doors for quality roller doors that keep on rolling